

THRUST BLOCK SCHEDULE BASED ON 2000 PSI
CONCRETE & 1500 PSF SOIL BEARING

REDUCER

REDUCER SIZE	AREA REQ'D	THRUST BLOCK SIZE
12X10	5.56 s.f.	2.4'X2.4'
12X8	9.32 s.f.	3.1'X3.1'
12X6	12.26 s.f.	3.5'X3.5'
10X8	4.43 s.f.	2.1'X2.1'
10X6	7.37 s.f.	2.7'X2.7'
8X6	3.38 s.f.	1.8'X1.8'

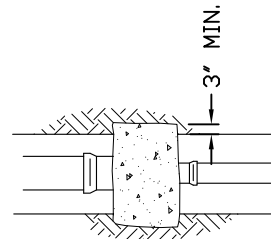

PLAN VIEW

VALVE ANCHORS

VALVE SIZE	AREA REQ'D	THRUST BLOCK SIZE
12	16.59 s.f.	4.1'X4.1'
10	11.51 s.f.	3.4'X3.4'
8	7.38 s.f.	2.7'X2.7'
6	4.15 s.f.	2.1'X2.1'

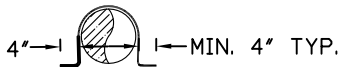

**BEND REBAR OUTWARD PERPENDICULAR TO ANGLE ENTERING CONCRETE

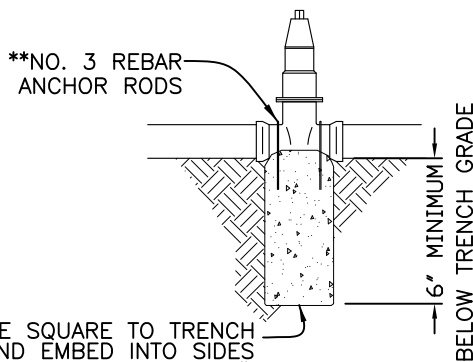

MUST BE SQUARE TO TRENCH BOTTOM, AND EMBED INTO SIDES OF TRENCH A MINIMUM OF 6".

NOTES:

1. ALL THRUST BLOCKS TO BE POURED AGAINST UNDISTURBED SOIL, PRIOR TO POURING. OMWC WILL TEST SOIL FOR COMPACTION. CONCRETE SHALL BE PLACED BEHIND BELL OF FITTING AND SHALL NOT COME INTO CONTACT WITH THE PIPE.
2. POLYETHYLENE PLASTIC FILM WRAP SHALL BE PLACED AROUND ALL BURIED DUCTILE IRON VALVES AND FITTINGS. FILM WRAP SHALL BE OF VIRGIN POLYETHYLENE AND MEET THE REQUIREMENTS OF ASTM D-1248 FOR TYPE 1, CLASS A, GRADE E-1 AND ASTM D-1238. FILM WRAP SHALL BE 10 MILS IN THICKNESS.
3. ALL THRUST BLOCKS SHALL BE ALLOWED TO CURE, UNDISTURBED, AND MUST BE APPROVED BY OMWC PRIOR TO BACKFILL.
4. CONCRETE STRENGTH SHALL BE 2000 PSI AT 28 DAYS MINIMUM AND SHALL NOT COME INTO DIRECT CONTACT WITH PIPE AND FITTINGS OR VALVES.
5. BEARING AREAS SHOWN IN TABLE HEREON ARE BASED UPON ALLOWABLE SOIL PRESSURE OF 1,500 PSF.

*REQUIRES CALCULATION

REV. DATE: 3/13/17

OILDALE MUTUAL WATER CO.

NON-POTABLE VALVE & REDUCER
THRUST BLOCK SCHEDULE

DATE: 8/1/13

PLATE No. IRR-9