

TOP OF CONCRETE
1/4" BELOW EXISTING
SURFACE

OLDCASTLE/CHRISTY
G5 BOX W/G5CT LID
SEE PLATE NO. 11

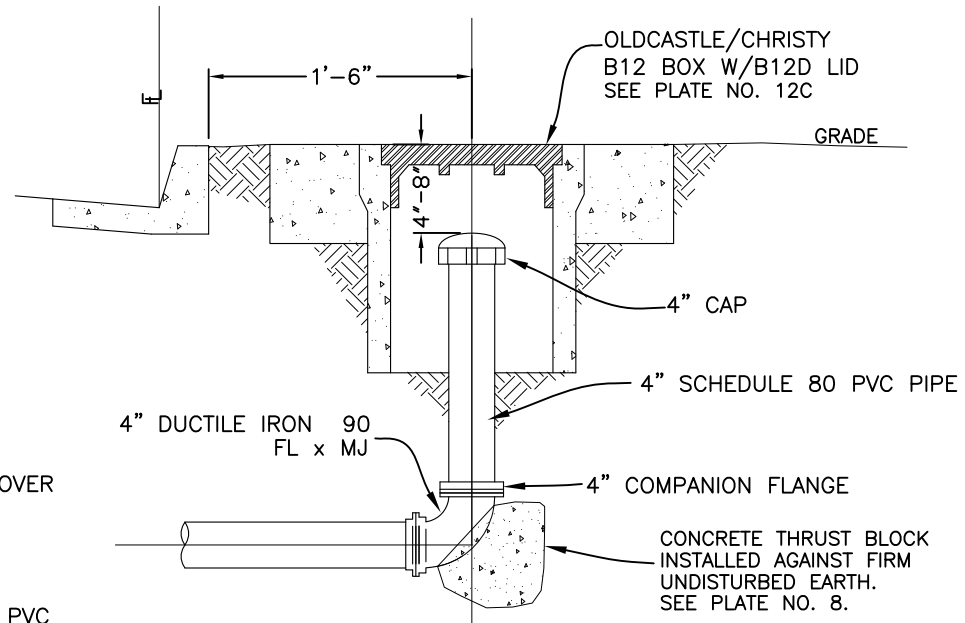
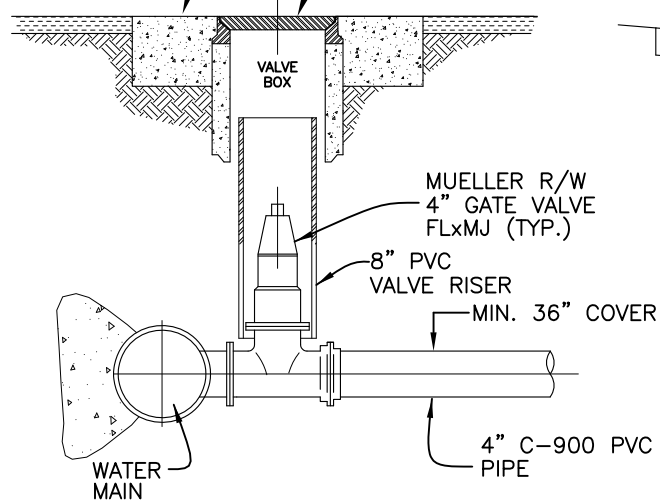

**4" BLOW-OFF
FOR 12" &
LARGER MAINS**

BLOW OFF ELEVATION
N.T.S.

REV. DATE: 1/2023

OILDALE MUTUAL WATER CO.

POTABLE/DOMESTIC TEMPORARY &
PERMANENT BLOW-OFF ASSEMBLY

DATE: 3/13/17

PLATE NO. 1C

NOTES:

1. ALL THRUST BLOCKS TO BE POURED AGAINST UNDISTURBED SOIL, PRIOR TO POURING. OMWC WILL TEST SOIL FOR COMPACTION.
2. POLYETHYLENE PLASTIC FILM WRAP SHALL BE PLACED AROUND ALL BURIED DUCTILE IRON VALVES AND FITTINGS. FILM WRAP SHALL BE OF VIRGIN POLYETHYLENE AND MEET THE REQUIREMENTS OF ASTM D-1248 FOR TYPE 1, CLASS A, GRADE E-1 AND ASTM D-1238. FILM WRAP SHALL BE 10 MILS IN THICKNESS.
3. ALL THRUST BLOCKS SHALL BE ALLOWED TO CURE, UNDISTURBED, AND MUST BE APPROVED BY OMWC PRIOR TO BACKFILL.
4. CONCRETE STRENGTH SHALL BE 2000 PSI AT 28 DAYS MINIMUM AND SHALL NOT COME INTO DIRECT CONTACT WITH PIPE AND FITTINGS OR VALVES.
5. SEE PLATES NO. 8 AND NO. 9 FOR THRUST BLOCK SIZING TABLES.

